

N.U.:Not used

CX-Z3A
MU-DEM UNIT
SCHEMATIC DIAGRAM(2/3)

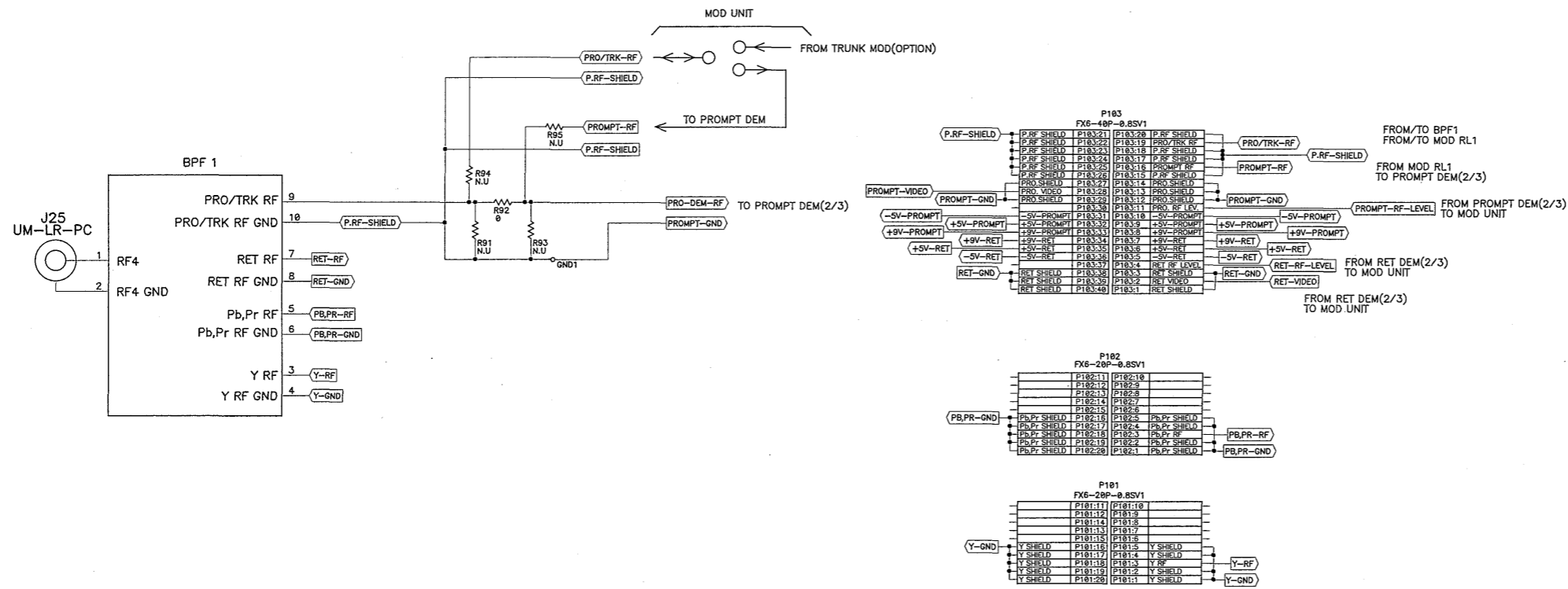

N.U:Not used

CX-Z3A
 MU-DEM UNIT
 SCHEMATIC DIAGRAM(3/3)

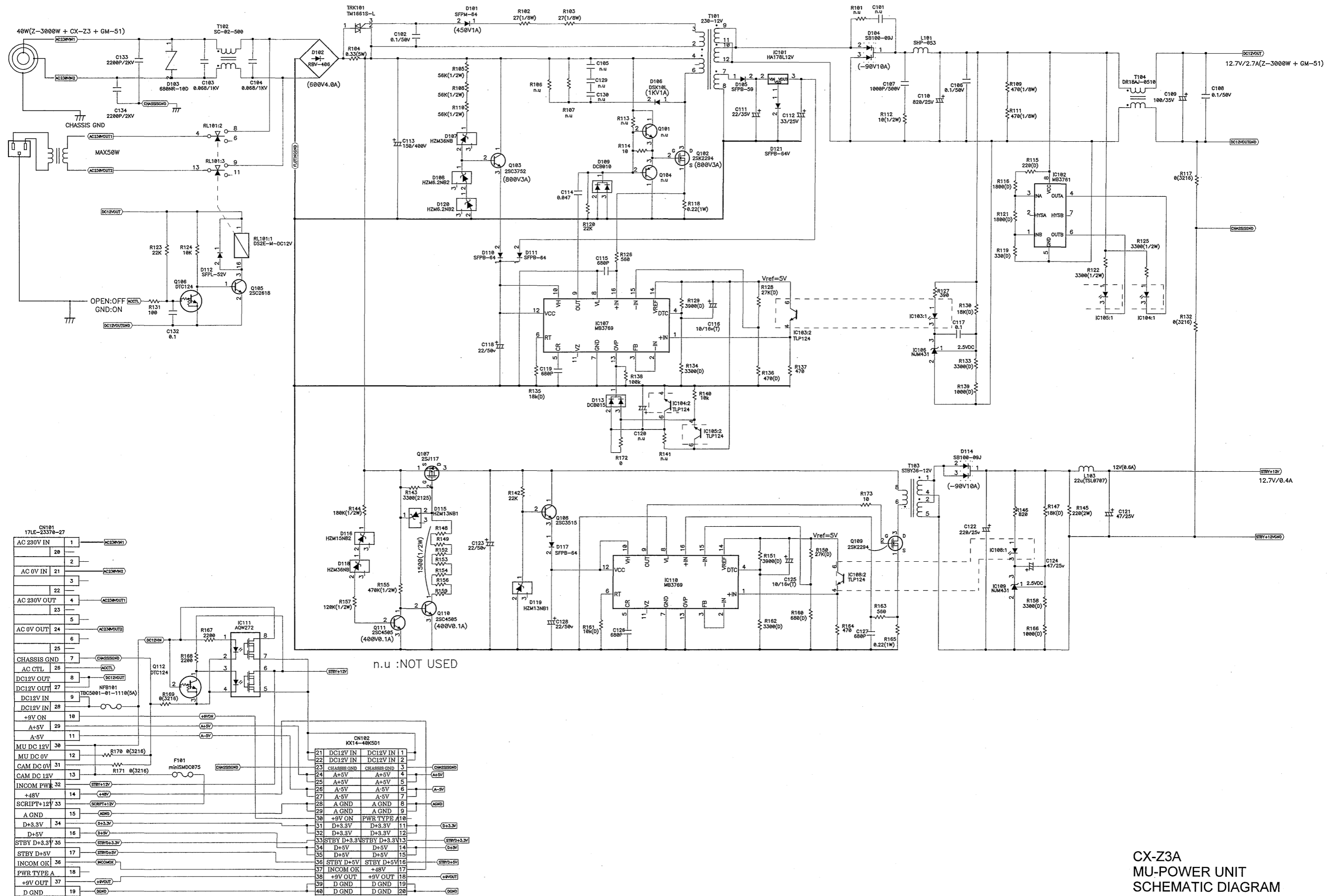

CX-Z3A
 MU-POWER UNIT
 SCHEMATIC DIAGRAM

CX-Z3A
 MU-PWR SUB UNIT
 SCHEMATIC DIAGRAM

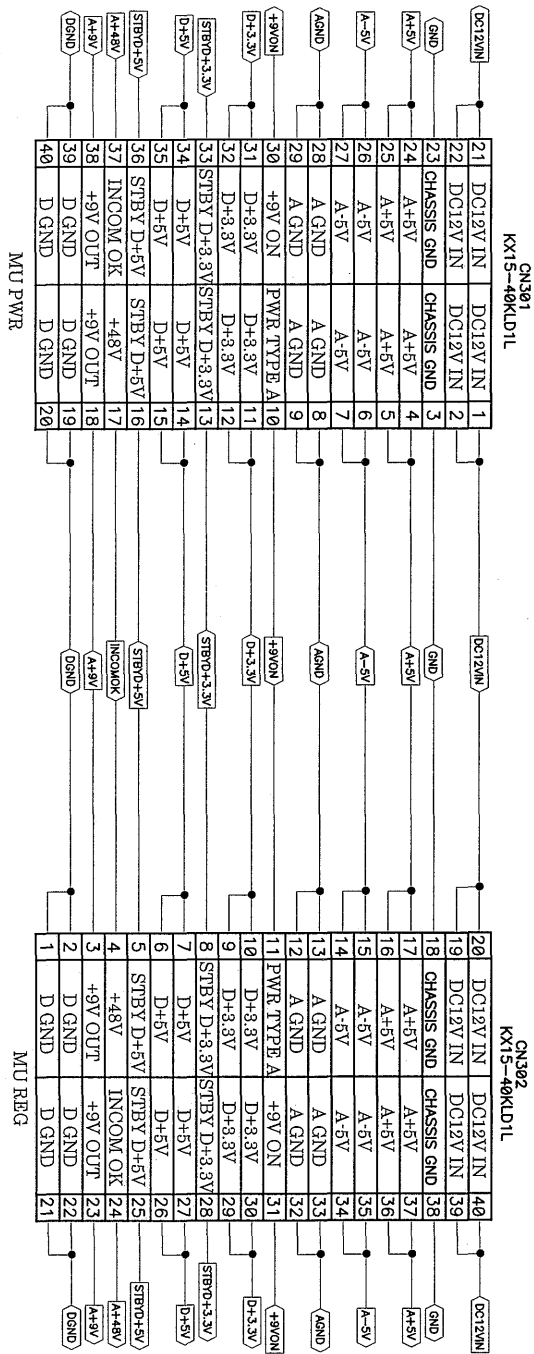

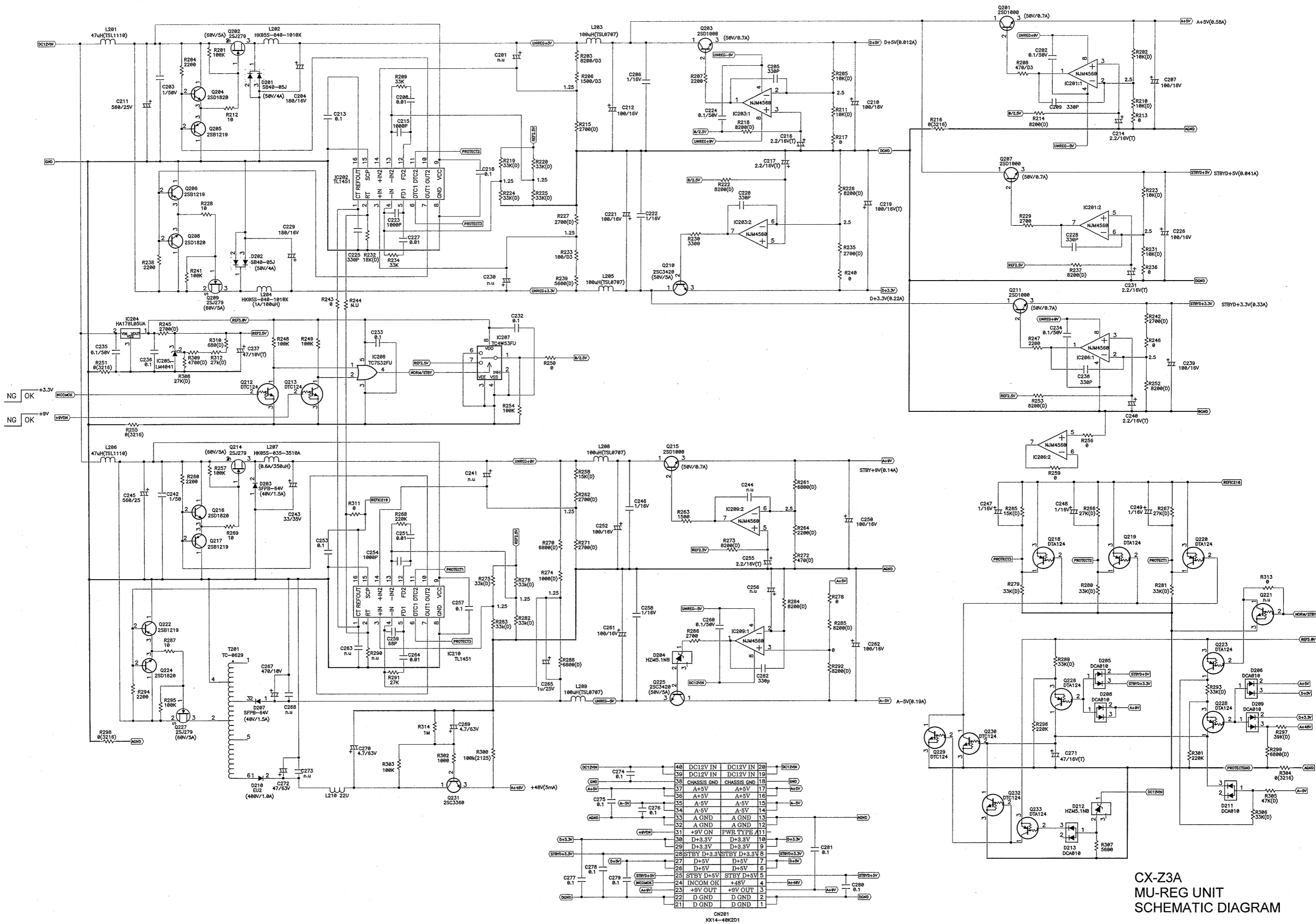

CX-Z3A
MU-REG UNIT
SCHEMATIC DIAGRAM

7. PARTS ARRANGEMENT

1. TU-Z3A

TU-MB unit	7-1
TU-VIDEO unit	7-3
TU-PWR/INCOM unit	7-5
DU-MOD/DEM unit	7-7
TU-RECT unit	7-8
INCOM/LED unit	7-9
TU-BNC unit	7-10
REMOTE unit	7-10
MIC unit	7-10
TU-DCIN unit	7-10
TU-RECT SUB unit	7-10
D1 OPTION unit	7-11

2. CX-Z3A

CX-MB unit	7-12
MU-DIGITAL unit	7-13
MU-INT unit	7-14
MU-MOD unit	7-15
MU-DEM unit	7-16
MU-POWER unit	7-17
MU-REG unit	7-18
FRONT PANEL unit	7-19
REAR 1 unit	7-20
REAR 2 unit	7-20
FIL-AC unit	7-20
INCOM SW unit	7-20
CALL unit	7-20
PWR SW unit	7-20
BNC unit	7-20
VF-AUX unit	7-20

7. ELECTRICAL PARTS ARRANGEMENT

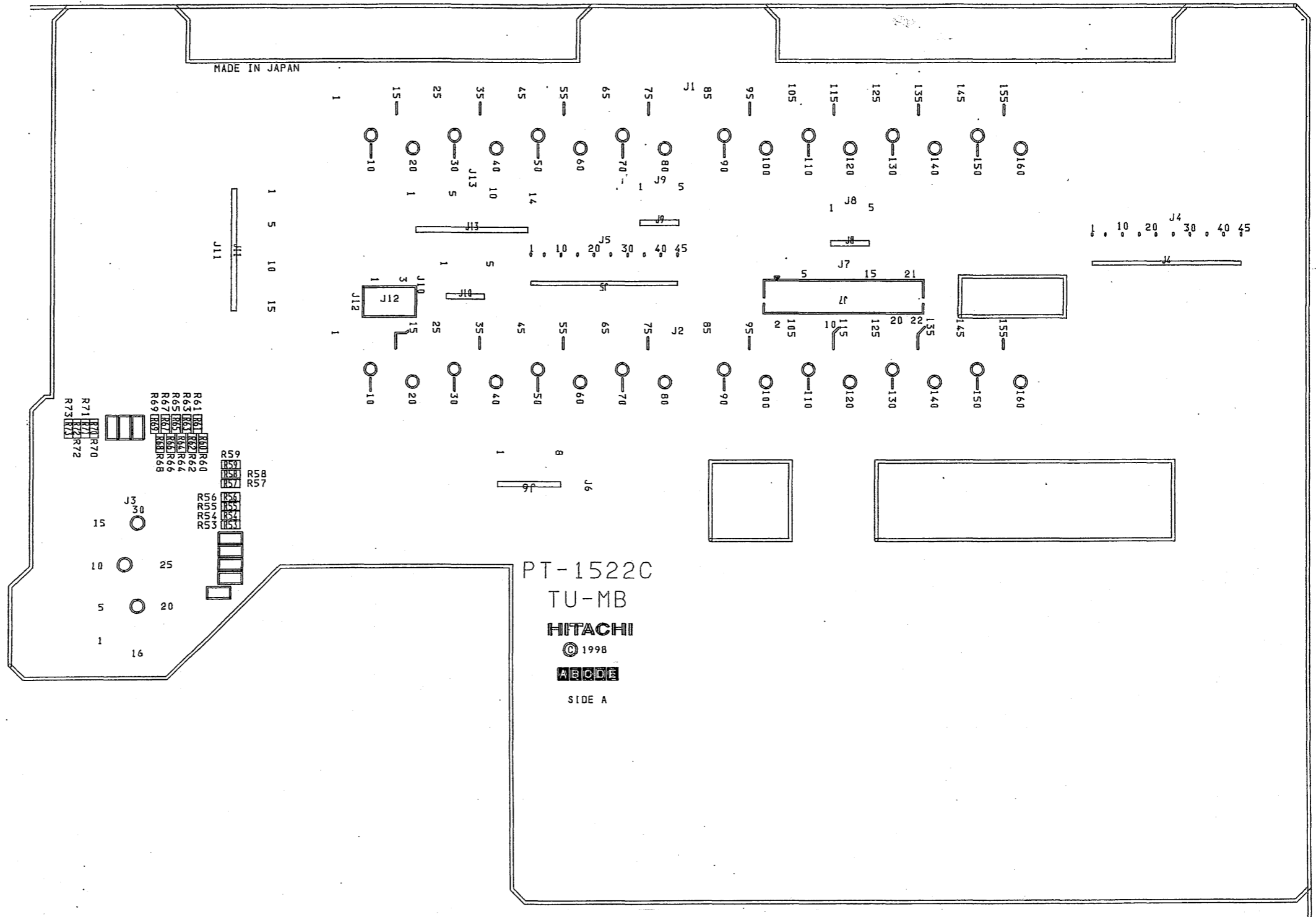

TU-MB (PT-1522C) SIDE A

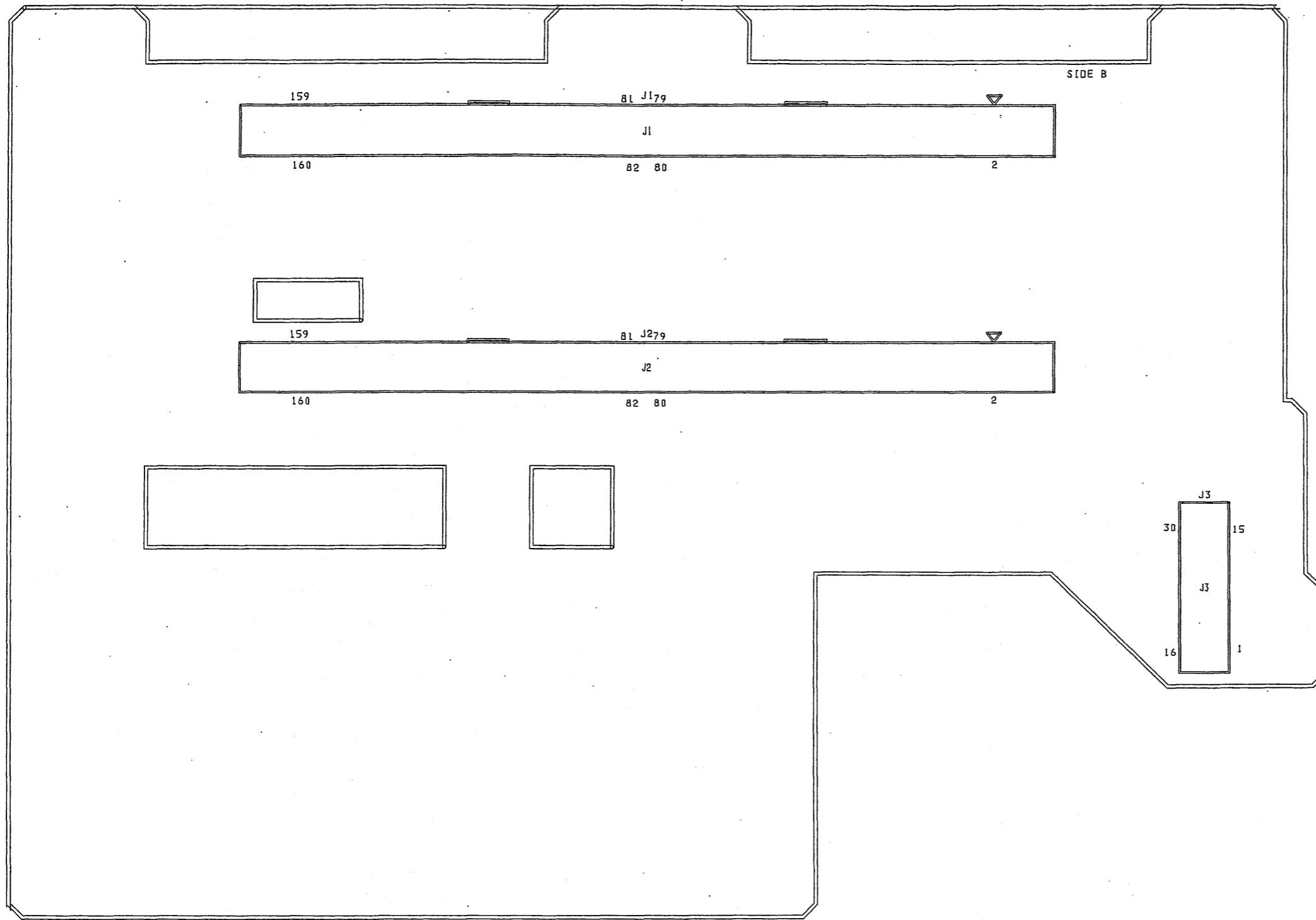

TU-MB (PT-1522C) SIDE B

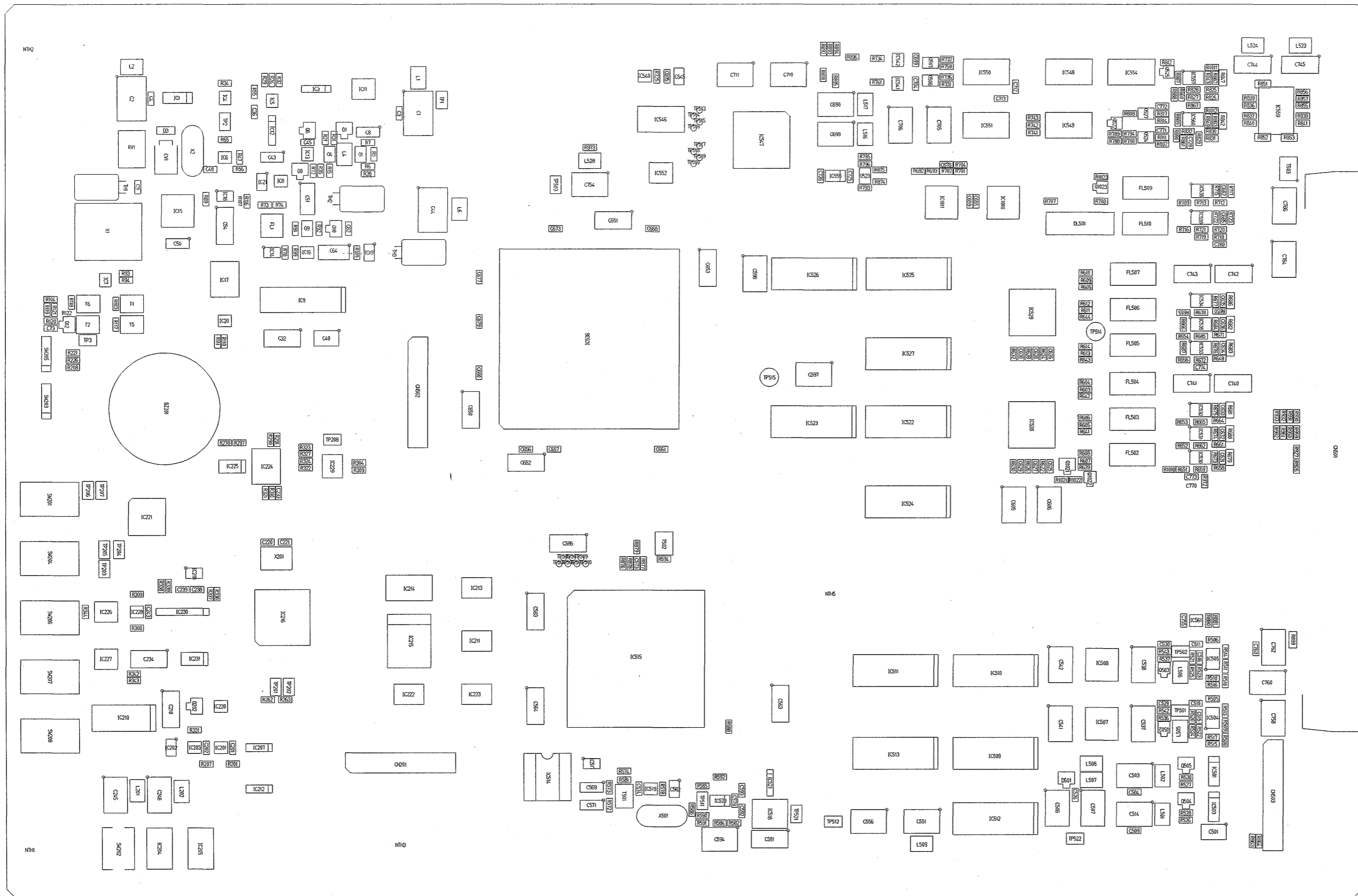

TU-VIDEO(PT-1518D) SIDE A